

SOCKET TYPE AND NO. OF POSITIONS	SOLDERTAIL SOCKET PART NUMBER WITHOUT POST	LOW INSERTION FORCE SOCKET PART NUMBER		
		WITH POST	WITHOUT POST	TAPE
PLCC 20	—	822270-1	822269-1	3-822269-1
PLCC 28	822437-1	822272-1	822271-1	3-822271-1
PLCC 32	822437-2	822274-1	822273-1	3-822273-1
PLCC 44	822437-3	822276-1	822275-1	3-822275-1
PLCC 52	822437-4	822278-1	822277-1	3-822277-1
PLCC 68	822437-5	822280-1	822279-1	3-822279-1
PLCC 84	822437-6	822282-1	822281-1	3-822281-1
SOJ 28●	—	—	822372-1	3-822372-1
SOJ 28●●	—	822363-1	822361-1	3-822361-1
SOJ 32●	—	—	822374-1	3-822374-1
SOJ 32●●	—	822364-1	822362-1	3-822362-1
SOJ 40●●	—	822267-2	822265-2	3-822265-2
SOJ 42●●	—	—	822378-1	3-822378-1
SOJ 44●●	—	—	822393-1	3-822393-1
SOJ 50●●●	—	—	822405-1	3-822405-1

- 7.62 mm [.300 in.] centerlines
- 10.16 mm [.400 in.] centerlines
- 10.16 mm [.400 in.] centerlines, 0.8 mm pitch

Figure 1

1. INTRODUCTION

This instruction sheet covers the use of AMP* Extraction Tool 822154-1. This tool is designed to remove chip carriers from the AMP surface mount low insertion force sockets, SOJ (Small Outline J-Leaded) sockets, and soldertail sockets listed in Figure 1.

NOTE

Dimensions are in millimeters [with inch equivalents in brackets].

Reasons for reissue of this sheet are provided in Section 5, REVISION SUMMARY.

2. DESCRIPTION

This tool is contoured for insertion into either of the two extraction cavities on the socket. By inserting the extraction tool with the correct angle (see Figure 2), and pivoting the tool on its heel against the socket, the chip carrier is easily removed.

3. EXTRACTION PROCEDURE

1. Orient the socket and tool as shown in Figure 3.
2. Insert the extraction tool into the socket so that the front angle of the tool is perpendicular to the chip carrier.

CAUTION Insertion of the extraction tool with an incorrect angle will result in damage to the socket. This incorrect angle will bottom under the stand-off rather than the bottom of the chip carrier.

3. Lower extraction tool into extraction cavity until it bottoms.
4. With a slight downward pressure, rotate the tool away from the chip carrier until the corner of the chip carrier lifts away from the socket.
5. Repeat on opposite extraction slot and lift chip carrier out of socket.

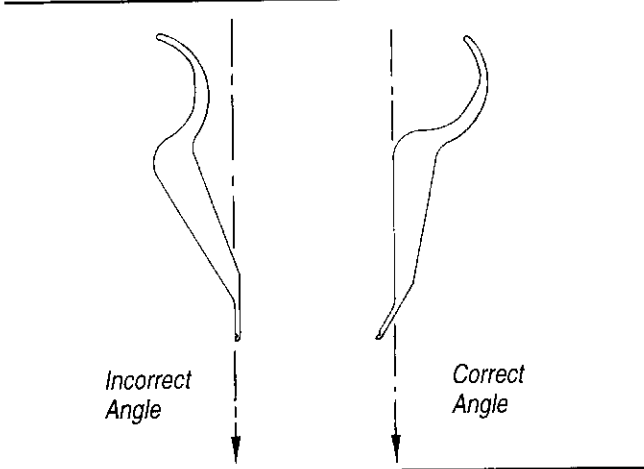
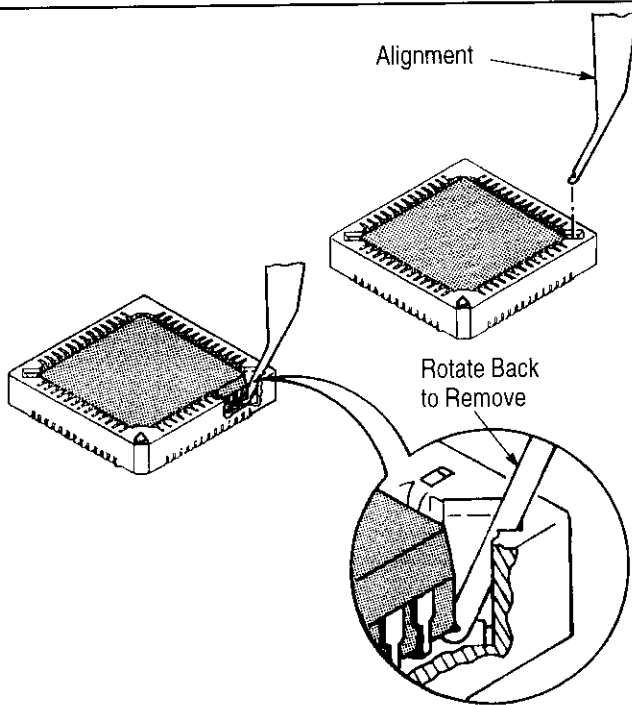

Figure 2



CAUTION: Do not attempt to completely extract chip carrier from socket on the first extraction. Lift from one side until the corner is above the socket, then repeat procedure on opposite corner.

Figure 3

4. TOOL INSPECTION

Extraction Tool 822154-1 has been inspected and should be verified with the information provided in Figure 4. It is recommended that the tool be inspected immediately upon its arrival at your facility (and at regularly scheduled intervals) to ensure that the tool has not been damaged during handling.

For additional information concerning extraction tools for PLCC and SOJ sockets, or to purchase additional tools, contact your local AMP representative or:

CUSTOMER SERVICE (38-35)
 AMP INCORPORATED
 P.O. BOX 3608
 HARRISBURG, PA 17105-3608

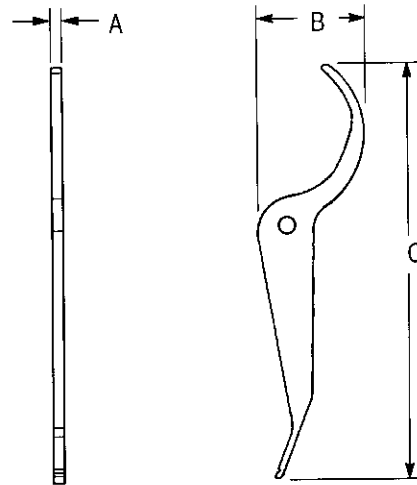

TOOL SPECIFICATIONS

PART NUMBER	DIMENSIONS		WEIGHT	MATERIAL
822154-1	A	1.27 ± 0.05 [.050 ± .002]	3.1 g [.11 oz]	Spring Steel Alloy
	B	18.54 ± 0.13 [.730 ± .005]		
	C	63.50 ± 0.13 [2.500 ± .005]		

Figure 4

5. REVISION SUMMARY

Revisions to this document include:

Per EC 0030-0143-96:

- Added information in Figure 1 for SOJ sockets (42, 44, and 50 positions)
- Removed all *standard* socket part numbers
- Added new soldertail socket part numbers