

2478- * - * - *

MATERIAL CODE
(.27)/.0106 THK
1=BRASS
3=PHOS BRONZE

WINDING SPEC.
A=PER ES-339-A
BLANK=PER ES-339-B
L=LOOSE

OPTION CODE
BLANK=AS SHOWN
C=CAT EAR OPTION
D=OPTIONAL CONDUCTOR CRIMP (FOR IRELAND) (SEE OPT. SECTION A-A) WITHOUT CAT EARS
E=LOW INSERTION FORCE OPTION

FINISH: PER SDES-88
(P909) *OVERALL HOT TIN DIP: 2.54 MICROMETERS MIN.
(550) SELECT GOLD: 0.38 MICROMETERS MIN, OVERALL GOLD FLASH: 0.05 MICROMETERS MIN, OVERALL NICKEL UNDERPLATE: 0.76 MICROMETERS MIN.
(555) SELECT GOLD: 0.38 MICROMETERS MIN, OVERALL NICKEL UNDERPLATE: 0.76 MICROMETERS MIN.

*THE PRIMARY SHIPPING CARTON WILL BE LABELED "COMPLIANT TO RoHS DIRECTIVE 2002/95/EC AND ELV ANNEX II OF DIRECTIVE 2000/53/EC". CARTONS WITHOUT THIS LABEL MAY CONTAIN PRODUCT WITH TIN/LEAD PLATING.

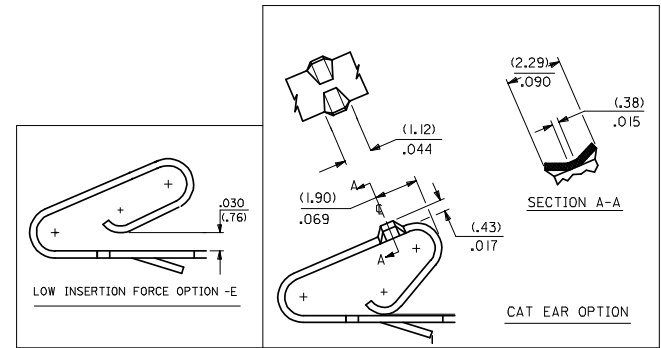
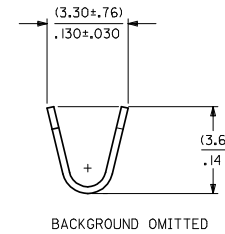
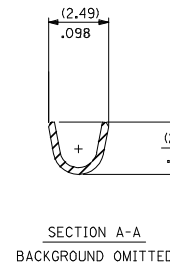
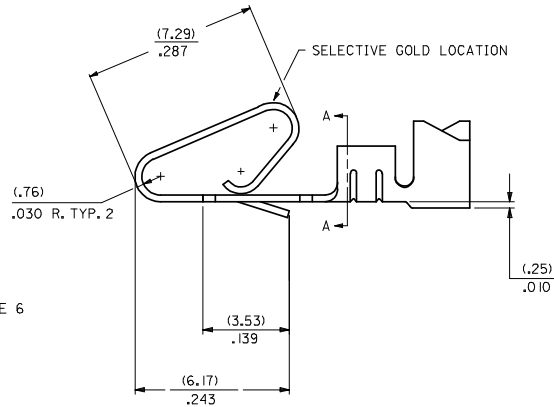
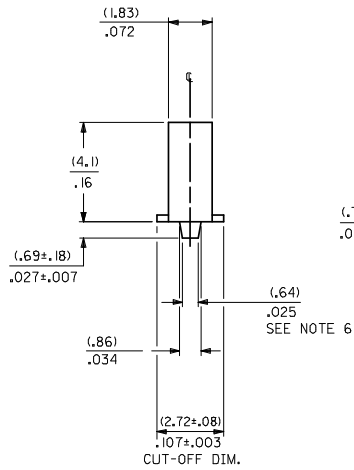

- NOTES:
- CRIMP ACCEPTS 18 TO 24 GA. WIRE WITH (2.79)/.110 MAX. INSUL. DIA.; WHEN USED WITH 2574 CONNECTOR, (2.54)/.100 MAX. INSUL. DIA. WHEN USED WITH 2139 CONNECTOR; HOUSING 41695 IS RECOMMENDED FOR OVER (2.54)/.100 DIA. INSULATION. CRIMP ACCEPTS (3.00)/.118 MAX. INSUL. DIA. WITH SPECIAL TOOLING.
 - DIMENSIONS GIVEN ACROSS CENTERLINES ARE SYMMETRICAL ABOUT THOSE CENTERLINES WITHIN HALF THE TOTAL TOLERANCE.
 -
 -
 -
 - (.86±.05)/.034±.002 IS AN OPTIONAL DESIGN.
 - THIS PART CONFORMS TO PRODUCT SPEC. 08-50.
 - CONDUCTOR CRIMP FOR 16 AWG. WIRE WITH .110 MAX. INSULATION DIA.

CHANGE TO ME10 EC NO: UCP2005-0902 DRAWN BY: DRWADRATNOL 2004/11/16 CHKD BY: CHKDSAMIEC 2006/03/28 APPROVED BY: APPRMMARJULIS 2004/10/28	QUALITY SYMBOLS ▽=0 ▽=0	GENERAL TOLERANCES (UNLESS SPECIFIED)		DIMENSION STYLE IN/MM		SCALE	DESIGN UNITS INCH	THIRD ANGLE PROJECTION
		4 PLACES ±.005 ±.005	3 PLACES ±.005 ±.010	2 PLACES ±.025 ±.014	1 PLACE ±.036 ±.014	ANGULAR ±1/2°	DRAWN BY: SAMIEC 06/03/86	DATE: 06/03/86
DRAFT WHERE APPLICABLE MUST REMAIN WITHIN DIMENSIONS		MATERIAL NO. SEE CHART		DOCUMENT NO. SD-2478		MOLEX INCORPORATED		
SIZE D		THIS DRAWING CONTAINS INFORMATION THAT IS PROPRIETARY TO MOLEX INCORPORATED AND SHOULD NOT BE USED WITHOUT WRITTEN PERMISSION		SHEET NO. 1 OF 2				

2478-1-(****)

PART NO.	ENG. NO.
08-50-0105	2478-1-(P909)
08-50-0106	2478-1-(P909)L
08-56-0105	2478-1-(550)
08-56-0106	2478-1-(550)L
08-55-0103	2478-1-(555)
08-55-0104	2478-1-(555)L
08-50-0146	2478-1-(109)
08-50-0147	2478-1-(109)L
08-50-0119	2478-1-(122)
08-50-0120	2478-1-(122)L
08-50-0271	2478-1-(P909)A
	2478-1-(507)
08-56-0153	2478-1-(507)L
08-56-0154	2478-1-(506)
	2478-1-(506)L
08-50-0015	2478-1-(102)
08-50-0016	2478-1-(102)L
08-52-0114	2478-1-(P909)
08-52-0115	2478-1-(P909)L
	2478-1-(132)
	2478-1-(132)L
08-50-0001	2478-1-(P224)
08-50-0006	2478-1-(P224)L
08-50-0063	2478-1-(224)
08-50-0064	2478-1-(224)L
08-55-0133	2478-1-(561)
08-55-0134	2478-1-(561)L
08-50-0073	2478-1-(P102)
08-50-0074	2478-1-(P102)L

2478-3-(****)

PART NO.	ENG. NO.
08-52-0071	2478-3-(P909)
08-52-0072	2478-3-(P909)L
08-65-0114	2478-3-(555)
08-65-0115	2478-3-(555)L
08-52-0073	2478-3-(P102)
08-52-0074	2478-3-(P102)L
08-52-0811	2478-3-(102)
08-52-0812	2478-3-(102)L
08-50-0281	2478-3-(122)
	2478-3-(122)L
08-58-0121	2478-3-(550)
08-58-0122	2478-3-(550)L
08-58-0103	2478-3-(591)
08-58-0104	2478-3-(591)L
08-58-0114	2478-3-(558)
08-58-0115	2478-3-(558)L

2478-IC-(****)

PART NO.	ENG. NO.
08-50-0014	2478-IC-(P909)
08-50-0045	2478-IC-(P909)L
08-50-0047	2478-IC-(P102)
08-50-0046	2478-IC-(P102)L
08-50-0091	2478-IC-(102)
08-50-0093	2478-IC-(102)L

2478-3C-(****)

PART NO.	ENG. NO.
08-52-0044	2478-3C-(P909)
08-52-0045	2478-3C-(P909)L
08-52-0023	2478-3C-(102)
08-52-0024	2478-3C-(102)L
08-52-0027	2478-3C-(122)
	2478-3C-(122)L
08-52-0047	2478-3C-(P102)L
08-52-0046	2478-3C-(P102)

2478-ID-(****)

PART NO.	ENG. NO.
08-50-0055	2478-ID-(P909)
08-50-0056	2478-ID-(P909)L

2478-3E-(****)

PART NO.	ENG. NO.
	2478-3E-(P909)
	2478-3E-(P909)L
	2478-3E-(555)
	2478-3E-(555)L
	2478-3E-(550)
	2478-3E-(550)L

SEE SHEET I	SEE SHEET I	DIMENSIONS SHOWN ARE IN INCH UNLESS OTHERWISE SPECIFIED DIMENSIONS ARE IN MILLIMETERS	DIMENSIONS SHOWN ARE IN METRIC INCH UNLESS OTHERWISE SPECIFIED DIMENSIONS ARE IN MILLIMETERS	CRIMP TERMINAL .156 18/24 AWG WIRE	
SEE SHEET I	SEE SHEET I			MOLEX INCORPORATED 13212 L.A. CA 91701 U.S.A.	SHEET NO. 2 DATE 06/12/86
SEE SHEET I	SEE SHEET I			PART NO. SD-2478 DRG. NO.	SEE CHARTS
SEE SHEET I	SEE SHEET I			DRG. NO. SD-2478 DRG. NO.	DATE 06/12/86
SEE SHEET I	SEE SHEET I			DRG. NO. SD-2478 DRG. NO.	DATE 06/12/86
SEE SHEET I	SEE SHEET I			DRG. NO. SD-2478 DRG. NO.	DATE 06/12/86
SEE SHEET I	SEE SHEET I			DRG. NO. SD-2478 DRG. NO.	DATE 06/12/86
LTR. REVISIONS	LTR. REVISIONS	DRG. NO. SD-2478 DRG. NO.	DATE 06/12/86	DRG. NO. SD-2478 DRG. NO.	