

SOCKET TERMINAL
42024-***

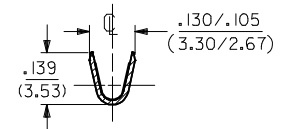

SECTION "B-B"
WIRE CRIMP AREA

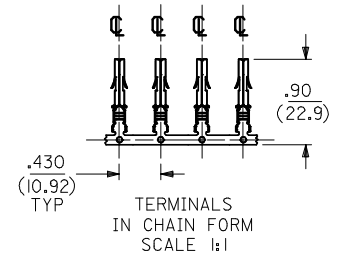
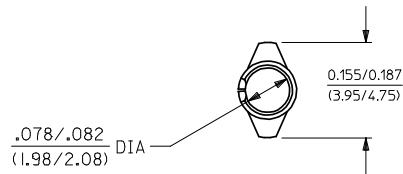
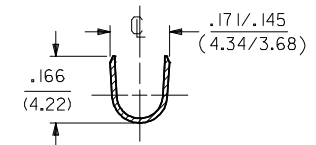

SECTION "A-A"
INSULATION CRIMP AREA

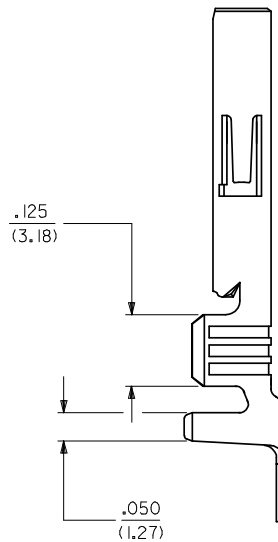
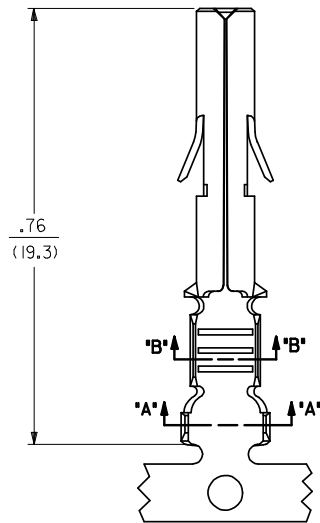

SEE SHEET 2 FOR CHART, MATERIAL, PLATING, NOTES, AND CRIMP OPTIONS

ENTER DESCRIPTION EC NO: 12008-0359 DRAWN BY: 2008/03/03 CHKD: VINU 2008/03/03 APPR: KPRASAD 2008/03/03	QUALITY SYMBOLS ▽=0 ▽=0	GENERAL TOLERANCES (UNLESS SPECIFIED)		DIMENSION STYLE	SCALE	DESIGN UNITS	THIRD ANGLE PROJECTION
		mm	INCH	IN/MM	4:1	INCH	☉ □
REV	DESCRIPTION	4 PLACES	± ---	± ---	DRAWN BY: SUDHIR	DATE: 2004/09/27	TITLE RMINAL, SOCKET 84/(2.13) DIA. SERIES
		3 PLACES	± ---	± .010	CHECKED BY: KPRASAD	DATE: 2004/09/27	
		2 PLACES	± 0.25	± .015	APPROVED BY: KPRASAD	DATE: 2004/09/27	MATERIAL NO. DOCUMENT NO. SHEET NO.
		1 PLACE	± 0.38	± ---	SEE CHART		
ANGULAR ±1/2°		DRAFT WHERE APPLICABLE MUST REMAIN WITHIN DIMENSIONS		THIS DRAWING CONTAINS INFORMATION THAT IS PROPRIETARY TO MOLEX INCORPORATED AND SHOULD NOT BE USED WITHOUT WRITTEN PERMISSION		MOLEX INCORPORATED SD-42024-**** 1 OF 2	

ENG. NO.	EDP NO.	FINISH (REF)	CONTACT AREA (REF)	CRIMP AREA (REF)	MATERIAL (REF)	WIRE SIZE	INSULATION DIA.
42024-IA1	002-08-1001	SDES-88-P901	----	----	C26000	#14-#20 AWG	.060-.130
42024-IA1L	002-08-1002	SDES-88-P901	----	----	C26000	#14-#20 AWG	.060-.130
42024-IB1	002-08-1003	SDES-88-P901	----	----	C51000	#14-#20 AWG	.060-.130
42024-IB1L	002-08-1004	SDES-88-P901	----	----	C51000	#14-#20 AWG	.060-.130
42024-IA2	002-08-1005	SEE NOTE 5	.000030 MIN GOLD	.000100 MIN MATTE TIN	C26000	#14-#20 AWG	.060-.130
42024-IA2L	002-08-1006	SEE NOTE 5	.000030 MIN GOLD	.000100 MIN MATTE TIN	C26000	#14-#20 AWG	.060-.130
42024-IB2	002-08-1007	SEE NOTE 5	.000030 MIN GOLD	.000100 MIN MATTE TIN	C51000	#14-#20 AWG	.060-.130
42024-IB2L	002-08-1008	SEE NOTE 5	.000030 MIN GOLD	.000100 MIN MATTE TIN	C51000	#14-#20 AWG	.060-.130

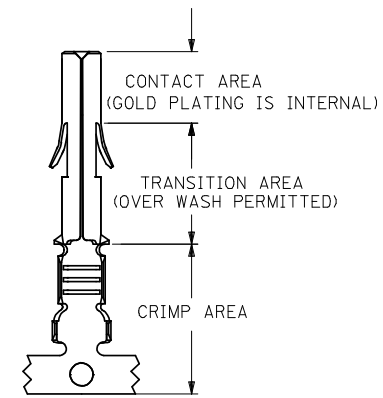

PLATING REGIONS

APPLIES TO GOLD PLATED TERMINALS ONLY

NOTES:

- SOCKET TERMINALS FOR USE WITH THE .084/(2.13) SERIES HOUSINGS:
 PLUG (42021-**)
 CAP (42022-**)
- SOCKET TERMINALS MATE WITH PIN TERMINALS: .084/(2.13) DIA. SERIES (42023-****).
- TERMINALS FINISHED IN CHAIN UNLESS SPECIFIED LOOSE. *L* SUFFIX INDICATES LOOSE FORM. (SEE TABLE)
- MATERIAL: .012/(0.30) THICK STRIP:
 A = BRASS, *C26000, PER SMES-124-C7.
 B = PHOSPHOR BRONZE, *C51000, PER SMES-124-E7.
- FINISH:
 1 = HOT TIN DIP 20 m.l./(.51 MICRONS) MINIMUM (PER SDES-88-P901).
 2 = 30 (M.I) / 0.75 MICRONS) MIN SELECT GOLD AND 100 (M.I) (2.50 MICRON) MIN SELECT TIN (MATTE) OVER 50 (M.I) (1.25 MICRONS) MIN NICKEL OVERALL
- CRIMP RANGE: SEE CHART.
- PRODUCT SPECIFICATION PS-42022-0001 APPLIES.

LEGEND:

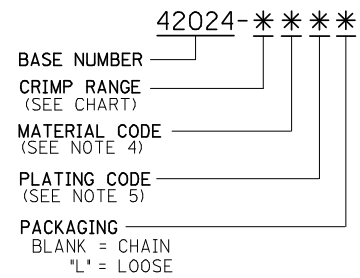

ENTER DESCRIPTION EC NO: 12008-0359 DRAWN BY: DRW:AB CHKD: VINI APPR: KPRASAD 2008/03/03 2008/03/03 2008/03/03	QUALITY SYMBOLS ▽=0 ▽=0	GENERAL TOLERANCES (UNLESS SPECIFIED)		DIMENSION STYLE IN/MM		SCALE ---	DESIGN UNITS INCH	THIRD ANGLE PROJECTION	
		4 PLACES	±---	±---	DRAWN BY: SUDHIR DATE: 2004/09/27	TITLE RMINAL, SOCKET 84/(2.13) DIA. SERIES			
		3 PLACES	±---	±---	CHECKED BY: KPRASAD DATE: 2004/09/27	MATERIAL NO. SEE CHART			
		2 PLACES	±---	±---	APPROVED BY: KPRASAD DATE: 2004/09/27	DOCUMENT NO. SD-42024-****			
DRAFT WHERE APPLICABLE MUST REMAIN WITHIN DIMENSIONS		ANGULAR ±---°		THIS DRAWING CONTAINS INFORMATION THAT IS PROPRIETARY TO MOLEX INCORPORATED AND SHOULD NOT BE USED WITHOUT WRITTEN PERMISSION		SHEET NO. 2 OF 2			